

# FLA3H

# PC Board Relay

 E173485

29.5×13×20.6



- Creepage distance:8.0mm Min
- Au-clad contact available
- Transparent sealed available
- Class B/F available
- Conform to RoHS,ELV directive

## CONTACT DATA

## CHARACTERISTICS DATA

Contact Form	2H/2Z
Contact Material	Silver Alloy
Load	Resistive load(COS Φ=1)
Contact Ratings	8A 250VAC 5A 30VDC
Minimum load	100mA 5VDC
Max Switching Voltage	250VAC/30VDC
Max Switching Current	8A
Max Switching Power	2000VA/240W
Contact Resistance	100m Ω Max at 6VDC 1A
Electrical	100, 000 Operations(at30Operations/minute)
Mechanical	10, 000, 000 Operations(at300Operations/minute)
Insulation Resistance	100M Ω Min at 500VDC
Between Open Contacts	1000VAC(for one minute)
Between Contacts and Coil	5000VAC(for one minute)
Operate Time	20ms
Release Time	10ms
Temperature Range	-40℃to+70℃
Shock Resistance	Operating Extremes: 10G
	Damage Limits: 100G
Vibration Resistance	10-55Hz, 1.5mm
Max. switching frequency	Mechanical: 18,000operations/hr
	Electrical: 1,800operations/hr
Humidity	40-85%
Weight	Approx 14g

## APPROVED STANDARDS

UL & cUL	8A 250VAC 5A 30VDC
----------	-----------------------

## COIL DATA

at 20℃

Coil Power 0.54W

Nominal Voltage (VDC)	Rated Current (mA)	Max Operate Voltage (VDC)	Min Release Voltage (VDC)	Coil Resistance (Ω ±10%)
3	180	2.4	0.15	17
5	108	4	0.25	46
6	90	4.8	0.3	67
9	60	7.2	0.45	150
12	45	9.6	0.6	270
24	22.5	19.2	1.2	1050
48	11.3	38.4	2.4	4250

Coil Power 0.72W

Nominal Voltage (VDC)	Rated Current (mA)	Max Operate Voltage (VDC)	Min Release Voltage (VDC)	Coil Resistance (Ω ±10%)
3	240	2.4	0.15	13
5	144	4	0.25	35
6	120	4.8	0.3	50
9	80	7.2	0.45	110
12	60	9.6	0.6	200
24	30	19.2	1.2	800
48	15	38.4	2.4	3200



FLOURISHING RELAY

NINGBO FLOURISHING PRECISION ELECTRON CO.,LTD

2008.12 B

## OPDERING CODE

<b>FLA3H</b>	<b>D</b>	<b>— 12VDC</b>	<b>— S</b>	<b>— 2Z</b>
1	2	3	4	5
1. Relay Model			4. S: Sealed	
2. Coil Power		D=0.72W, L=0.54W	5. Contact Form	
3. Coil Nominal Voltage		3,5,6,9,12,24,48VDC	2Z: Form 2C	
			2H: Form 2A	

**OUTLINE DIMENSIONS, WIRING DIAGRAM AND LAYOUT**

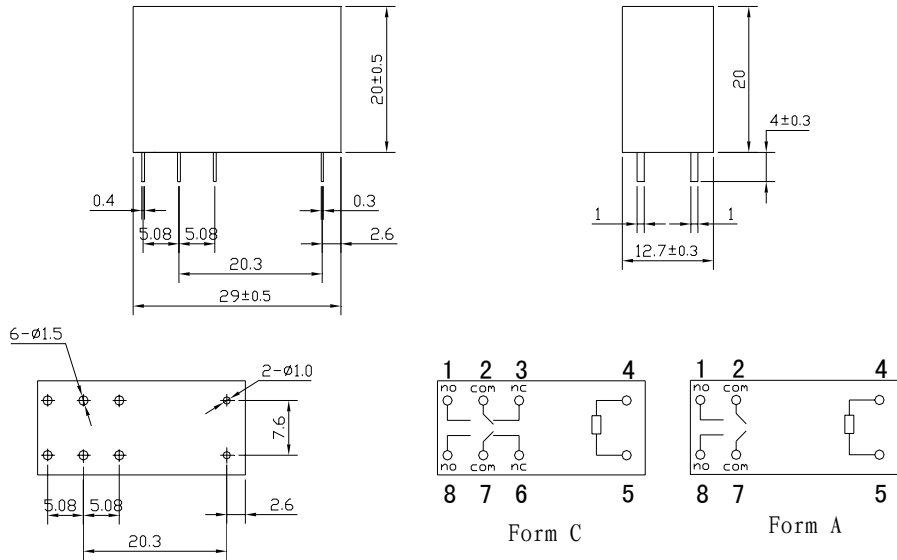

Layout (Bottom View)

**ENGINEERING DATA**

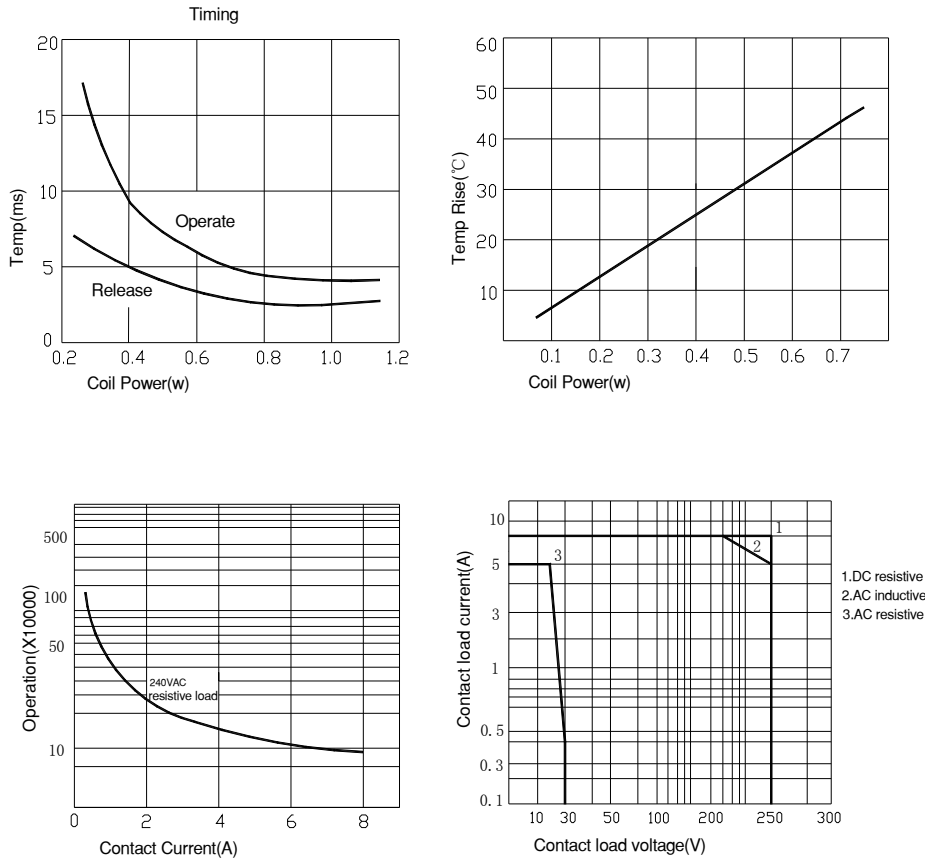

**FLOURISHING RELAY**

The specifications are for the customer's reference and are subject to change without notice.